

www.organicwastecompost.com
www.smshydro.com



SMS HYDROTECH

CORPORATE BROUCHER

Waste Management Machines & Services
We Believe in to Provide Our Best Services.



ABOUT US

SMS Hydrotech is counted among the reputed manufacturer, supplier and exporter of a broad range of Hydraulic cylinders, tractor and auto components. We also deal with Waste Management Machines and Services.

Our mission is "CLEAN AND GREEN PLANT TO ENHANCE BETTER LIVING".

Our products are acknowledged for features including reliable performance sturdy built, long service life and ease of installation and usage. We can design and develop these products and machines in different specifications to suit the varied requirements of the clients.

Our professionals help us in offering customization facility to the clients.

HISTORY OF THE COMPANY

The Company "SMS Hydrotech" was started by MR. S.P SINGH IN 1978 as he did B.E from IIT - Rorkee and growing this business since from that lime and now having a great huge client base with better client satisfaction rate and provided their services or products to many industries.

Now from 2009 his son "Mr. Surya, Vikram Singh" who did his B.E. from Middlesex University, London, Joined this business to promote and support this business to the next level and maintain the business in a much better way with modern techniques.

Apart from this. the company also holding many certifications like ISO and deals in all types of critical components and continuous efforts for the new development and Quality.

INFRASTRUCTURE

Our products are manufactured in the plants, which is equipped with all modern production facilities. The facilities contribute to our capacity to conform to the international standards ensuring top quality performance & reliability. Besides. We are also engaged in vigorous R&D activities. Our Research & Development laboratory is armed with modern measuring instruments and precision computerized testing facilities.

MACHINERY IN-HOUSE FACILITIES

- 8 Turning CNC
- 3 VMC
- 1 M1TR fully automatic
- 8 Honing machines
- 1 CNC fully automatic Honing machine
- 8 Lathe machine
- 5 Drilling machine
- 1 Radial Drilling machine
- 1 Horizontal boring machine HMT
- 1 Surface grinder
- 2 Band saw
- Hydraulic Pressure testing
- 2 Mig welding machine
- 2 Welding SPM
- Buffing machine
- Centerless Grinder
- Surface finish tester
- 6 Arc welding
- Cutter & Grinders
- Bending Machine
- All inspection instruments with calibration report

1400sq YR working area in existing two plants and 2 approved Industrial plots available for future expansion

ORGANIC/FOOD WASTE MACHINE

HOW ORGANIC/ FOOD WASTE WORKS?

Our Food waste machine is a fully automatic and highly compact composting machine which uses special technique to break down and decompose all kinds of organic waste into compost within 24 hrs with a volume reduction of 80-90%. The entire process is natural and biological.

Our Food waste machine has an inbuilt shredder, composting tank with a humidity sensor, heater, mixing blades, moisture control system and air ventilation system.

When organic/food waste is added to it, shredder shreds organic/food waste into small pieces and transfers all shredded material to composting tank. Artificial atmosphere for quick decomposing is created in the machine. At the same time our special composting enzyme or saw dust mixture decomposes the organic waste into compost and this happens within 24 hours. That's how we achieve 85-90% volume reduction. The process is completely noiseless and odour free.

MOST SUITABLE FOR:

Resorts, Hotels, Residential Complexes, Mall (with food courts), Marriage Halls, Canteens, Educational Institutes (with canteen facility)



OUTPUT PRODUCT:

Compost / Organic Manure / Soil Amendment Product

FEATURES:

- Inbuilt Shredder
- Fully automatic PLC based machine mechanism with minimum human intervention
- Zero discharge and no emission of harmful gases.
- 100% natural 24 hours composting process
- Compact in size and easy to operate
- High quality Organic Compost ready to use in 24 hours
- S.S 304 Machine Fabrication
- Decentralized solution for organic food waste management
- Noiseless, Odourless, Maintenance-free.
- No enzymes used.
- Reduces large amounts spent on transportation to landfill sites
- In-house waste management reducing dependence on any third party
- Plug and play operation need basic shed and foundation only

Capacity/Model With inbuilt Shredder	Machine Size in Ft L X B X H	Power in H.P	Machine Weight Kg	Material of Construction	Delivery Time
25Kg/day FS002	4.5 x 4.5 x 4.5	1	600	SS 304	20-25 days
50Kg/day FS011	5 x 5 x 5	2-3	900	SS 304	20-25 days
100Kg/day FS015	5 x 5 x 5	2-3	950	SS 304	20-25 days
150Kg/day FS016	5.5 x 5 x 5	2-3	1050	SS 304	20-25 days
200Kg/day FS020	5.5 x 5 x 5	3-5	1100	SS 304	20-25 days
250Kg/day FS025	6 x 5 x 5	3-5	1250	SS 304	20-25 days
500Kg/day FS055	6 x 5.5 x 5.5	5-10	2600	SS 304	30-45 days
750Kg/day FS075	6 x 5.5 x 6	5-10	2800	SS 304	30-45 days
1000Kg/day FSK099	9.5 x 6 x 6	10-15	3200	SS 304	45-55 days
2000Kg/day FSK029	18 x 6 x 7	20-25	4200	SS 304	45-55 days
3000Kg/day FSK039	21 x 7 x 7	25-35	4700	SS 304	45-55 days



HORTICULTURE/AGRICULTURE WASTE RECYCLING MACHINE

HOW HORTICULTURE/ AGRICULTURE WASTE RECYCLING MACHINE WORKS?

Horticulture/Agriculture waste recycling machine uses special technique to recycle all kinds of garden waste into bio-fuel pellets. This bio-fuel product will be a future source of renewable energy for Generating Electricity.

Our Horticulture/Agriculture waste recycling machine can convert dry leaves, wood, grass, dry flowers, twigs, wood logs up to 10-15mm into pellets which can be used for multiple applications i.e. burning fuel, Compost, cooking fuel which is less harmful than coal.

Our machine is a fully automatic and highly compact machine which use special technique to shred horticulture waste into small pieces. Our Horticulture/Agriculture waste recycling machine has a special chamber in which we create artificial environment and control shredded material temperature and moisture. Then that material travels towards our pelleting unit which converts that shredded material into bio-fuel pellets. This bio-fuel product will be a future source of renewable energy for Generating Electricity. These bio-fuel pellets can be used for smokeless Chulhas in villages. We can use them in industries for heating up boilers and furnaces also.

Output product- This bio-fuel pellets which have good calorific value as compared to charcoal.

MOST SUITABLE FOR:

Resorts, Hotels, Residential Complexes, Mall (with food courts), Marriage Halls, Canteens, Educational Institutes (with canteen facility)

FEATURES:

- Working on the principal of providing complete Bio-Fuel pelleting system in a single machine.
- Outer body is made with Sturdy material to make sure maximum life of the machine.
- Our Machine has inbuilt shredder which shreds dry leaves, wood, grass, dry flowers, twigs, wood logs up to 10-15mm.
- Our Horticulture/Agriculture waste recycling machine has an inbuilt humidity sensor and moisture generation system.
- Our Horticulture/Agriculture waste recycling machine has a separate pelleting unit which converts the shredded material into bio-fuel pellets.
- Low power consumption.
- Easy to operate and maintain.

Name Model	Power KW with Shredder while reeding	Power KW During Biomass Pelleting process	Product	Approx Dimensions
Gs011 50Kgs-60Kgs	9 KW	4.5 KW	Biomass Pellets	4 x 3.5 x 5.5
Gs015 100Kgs-110Kgs	9 KW	4.5 KW	Biomass Pellets	5.5 x 3.5 x 5.5
Gs025 250Kgs-260Kgs	10 KW	6 KW	Biomass Pellets	7 x 4.6.5
Gs055 550Kgs-600Kgs	11 KW	6 KW	Biomass Pellets	10 x 5.5 x 7
Gsk099 1000Kgs	15 KW	7 KW	Biomass Pellets	13.9 x 4.8 x 8



INDUSTRIAL SHREDDERS

Types of Industrial Shredder:

- Horticulture/Agriculture Waste Shredder
- Plastic Waste Shredder
- Food Waste Shredder
- Tire Waste Shredder

HORTICULTURE WASTE SHREDDER

Capacity Available:

50Kg/hr, 100Kg/hr, 250Kg/hr, 500Kg/hr and 1000Kg/hr

Shredder Output:

Powdered / Chipped / Saw Dust

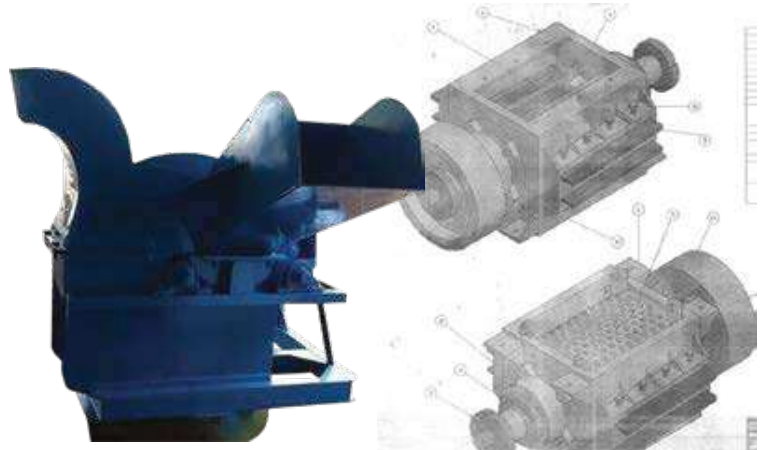

PLASTIC WASTE SHREDDER

Capacity Available:

50Kg/hr, 100Kg/hr, 250Kg/hr, 500Kg/hr and 1000Kg/hr

Shredder Output:

Shredded Plastic Waste



FOOD WASTE SHREDDER

Capacity Available:

50Kg/hr, 100Kg/hr, 250Kg/hr, 500Kg/hr and 1000Kg/hr

Shredder Output:

Shredder Food Waste / Food Slurry



TIRE WASTE SHREDDER

Capacity Available:

50Kg/hr, 100Kg/hr, 250Kg/hr, 500Kg/hr and 1000Kg/hr

Shredder Output:

Mixed Shredded Tire Rubber



Shredder Video links:

Food/ Organic Waste Shredder: <https://youtu.be/b8oaNL5bNXU>

Plastic Waste Shredder: <https://youtu.be/s8gxCX5lycM>

Heavy Duty Shredder: <https://youtu.be/KTLLLONo2F8>



TRACTOR AND AUTO COMPONENTS

PRODUCTS

List of Products:

- Hydraulic Cylinder for tractor
- Hydraulic cylinders for hydraulic lifts and trains
- Three point linkage for tractors
- Shocker cover for trains
- Coupler Assembly for trains
- Pistons for tractor and auto industry
- Casing tube
- Hydraulic power pack
- Hydraulic cylinder unit or Hydraulic motor
- Flange
- Boll joint
- Shredders
- Waste Management Machines.

CUSTOMIZATION R&D DEPARTMENT

SMS has the necessary expertise to create new designs, prototype for clients in various parts of the India. Our designers and engineers are equipped to make a counter sample of the sample or a drawing you sent us within a few weeks and that too strictly according to the required specifications.



CLIENTS FOR TRACTOR AND AUTO COMPONENTS



Tafe (Eicher tractors)
OEM vendor since last 32 years
Component: - Hydraulic cylinders and bearing spacers



ACE tractors
OEM vendor since last 4 years
Component:- Engine rear cover and hydraulic cylinders



Escorts Railways
OEM vendor since last 3 years
Component:- Hyd



JBM Ltd.
OEM vendor since last two years
Component:- Ball Joints



CLIENTS FOR WASTE RECYCLING MACHINES



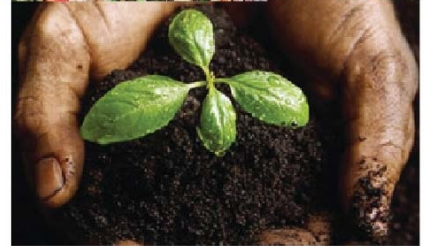
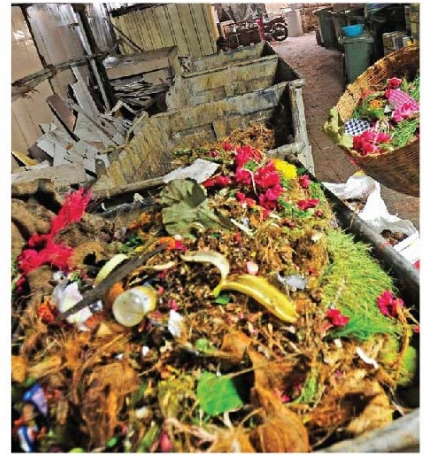

SMS HYDROTECH

SMS HYDROTECH

Plot No: 325, Sector 24,
Faridabad, Haryana, India
121005

+91-9811853399, +91-9811611599
+91-9871443868